

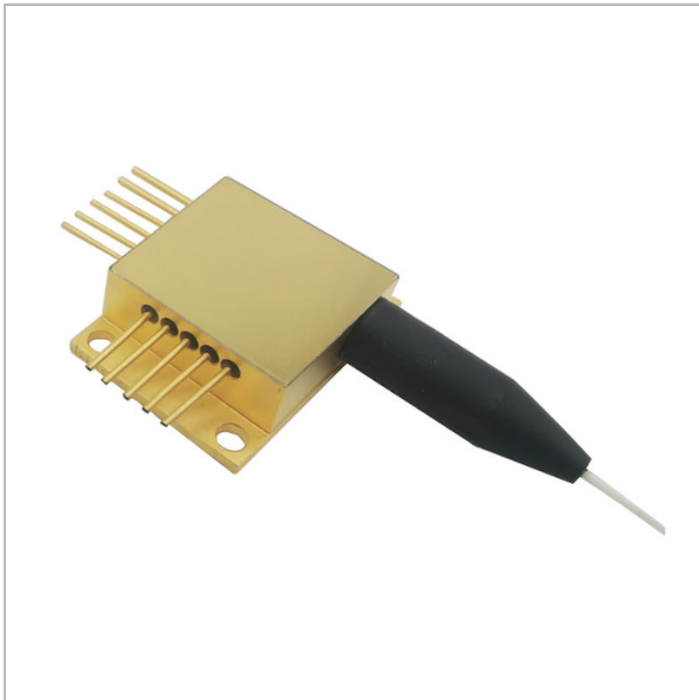

Offered by
LASER LAB SOURCE

manufactured by  **RealLight**

980nm High Power Fiber-Coupled Laser Diode 15W Output Power, 105 μ m Fiber



RLS / 980NM-15W-105UM-RL

- o High Heat Load Package Laser Diode
- o 105 μ m Fiber Core; 200 μ m Core Fiber Also Available (Inquire)
- o Integrated Thermistor, Photodiode and Red Aiming Beam
- o FC/PC Connector or SMA905 Connector
- o Robust and Rugged Construction



**LASER
DIODE
SOURCES**



FIBER-COUPLED HHL LASER DIODE

These multimode high heat load-packaged lasers deliver high power via the 105µm core fiber. Alternately, 200µm core fiber is also available; inquire for details.

RELIABLE PERFORMANCE IN A STANDARD LASER PACKAGE

The laser is designed and constructed to provide stable output and a long operating lifetime.

The laser includes an internal photodiode for power monitoring, and the integrated thermistor enables precision temperature control for wavelength and power stability. The laser also features a separately controlled low-power aiming beam.

DIMENSIONS AND PINOUT

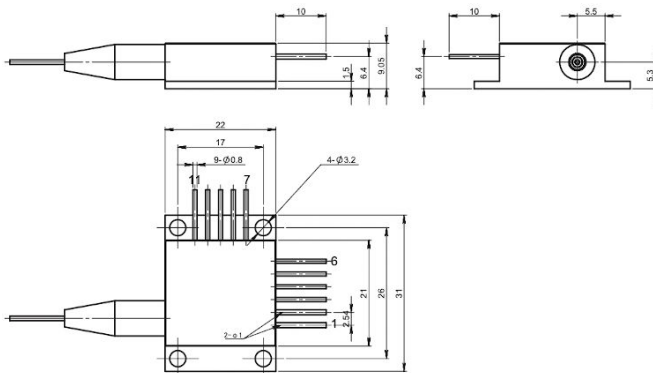

Pin	Function	Pin	Function
1	Laser (+)	7	Thermistor
2	Laser (-)	8	Thermistor
3	PD (N)	9	Aiming Beam (+)
4	PD (P)	10	Aiming Beam (-)
5	-	11	-
6	-		



SPECIFICATIONS - 980NM-15W-105UM-RL

LASER SPECIFICATIONS

- CW Output Power: 15 W
- Center Wavelength: 980 nm (±10 nm)
- Spectral Width: < 4 nm
- Temperature Tuning Coefficient: 0.3 nm/°C

FIBER AND CONNECTOR

- Fiber Core Diameter: 105 µm
- Fiber Cladding Diameter: 125 µm
- Fiber Coating Diameter: 250 µm
- Numerical Aperture: 0.22 NA
- Connector: FC/PC or SMA905 (specify @ time of order)
- Fiber Length: 100 cm ±10 cm
- Alternate Fiber: 200µm Core / 220µm Clad (Inquire for Availability and Specifications)

ELECTRICAL SPECIFICATIONS

- Threshold Current: 0.7 A
- Operating Current: 18 A
- Operating Voltage: 1.9 V
- Monitor Photodiode Range: 2000 µA
- Thermistor: 10 (±5%) kΩ (@25°C)
- Slope Efficiency: 0.9 W/A

AIMING BEAM SPECIFICATIONS

- Output Power: 2 mW
- Wavelength: 650 nm ±10 nm
- Forward Voltage: 2.2 V

GENERAL SPECIFICATIONS

- Operating Temperature Range: 10°C – 30°C
- Storage Temperature Range: -20°C – 70°C
- Max Operating Humidity, Relative: 75 %
- Max Storage Humidity, Relative: 90 %
- Lead Soldering Temp: 250°C max, 10 sec

PRIMARY APPLICATIONS

- Raman Spectroscopy
- Analytical Instruments
- Pumping Applications



Offered by
LASER LAB SOURCE



**LASER
DIODE
SOURCES**

PRODUCT SALES AND SERVICE:

Unlimited phone and email support is provided for products purchased through Laser Lab Source. Orders for this product are fulfilled by Laser Lab Source in North America and select international regions. It is manufactured by Real-Light, Beijing.

PRODUCT WARRANTY:

This product is sold with a full one-year warranty. It is warranted to be free from defects in material and/or workmanship for a period of one year from the date of shipment.



Laser Lab Source, a division of Research Lab Source, Inc.
670 S. Ferguson St., Suite 3
Bozeman, MT 59718 USA

Phone: 406-219-1472

www.LaserLabSource.com



5th floor Block F No.1 Building
No.139 Jinghai 3rd Road
Beijing Development Area
Beijing, China