

Butterfly Laser Diode Mount

- No Jumper Wires to Set Simply Choose the Correct Model & it Ships Pre-Configured for Your Laser Diode
- Proprietary Flex-PCB Mount Socket Eliminates the Problem of Bending Leads (common to ZIF sockets)
- Includes Graphite Thermal Mounting Pad for Maximum Temperature Stability
- Option for Additional Peltier Cooler to Control the Butterfly External Case Temperature
- Thermal Resistance $R (th) < 1.2 \text{ C/W}$
- Ultra-Compact 60mm x 64mm x 53mm

LDM-BUTTERFLY-X DATA SHEET

**WORLD LEADING PRODUCTS
FOR LASER SCIENTISTS AND ENGINEERS**

DATA SHEET

LDM-BUTTERFLY-X Product Overview:

The model LDM-BUTTERFLY-X is a butterfly laser diode mount which ships fully pre-configured for your 14-pin packaged laser diode. There are models available to accommodate butterfly packages from all laser diode manufacturers. They offer uniform heat dissipation and very high thermal stability, making them an excellent choice for spectroscopy or telecom testing applications. This compact butterfly mount can also be TEC controlled from an optional integrated Peltier cooler. This case temperature control option allows the case of the package to be controlled in parallel with the internal chip cooler. These mounts also offer a graphite thermal pad, "mounting pad", which quickly and uniformly transfers waste heat away from the butterfly package to keep the temperature stable at your desired set-point.

Proprietary Mount Design Prevents Bending Leads:

Instead of the commonly Azimuth ZIF zero insertion force socket mounting architecture, this butterfly package mount uses a proprietary spring loaded PCB base with a plastic top clamping arm. This proprietary design allows the user quickly install and remove the butterfly laser module without bending the package leads, a very common problem when using a ZIF socket. The PCB base has gold traces for the 14 pins of the butterfly, and the flexure of the PCB eliminates the problem of lead bending.

In addition to laser diode anode and cathode electrical connections, the LDM-BUTTERFLY offers pinned connections to the internal Peltier / TEC cooling element, the thermistor and the monitor photodiode connections which are common to 14-pin butterflies. The internal TE cooler is typically controlled by the feedback from the laser diode's internal 10 kOhm thermistor.

Key Applications and Configurations:

The LDM-BUTTERFLY is used to mount and thermally stabilize laser diodes used in tunable diode laser spectroscopy. For spectroscopy applications, many users choose the optional high stability case temperature control model. This model offers active temperature control of the case through the additional embedded TEC. These mounts are also used extensively for mounting fiber laser pumps and pumps in other solid state lasers. For pump applications, the user typically chooses the passively cooled model which relies on the internal TEC / Peltier cooler for thermal stabilization.

Single 15-Pin D-SUB Electrical Connector:

These mounts offer a simple connection point to the laser driver and temperature controller. A single 15-pin D-SUB connector offers the user access to all of the butterfly pins.

LDM-BUTTERFLY-X SPECIFICATIONS

GENERAL SPECIFICATIONS

Package Style:	14 Pin Butterfly (see pin configuration options below)
Maximum Laser Diode Bias Current:	4 Amps
Maximum TEC Current:	5 Amps
Graphite Thermal Pad Thickness:	70 μ m
Flex-PCB Mounting Pin Material:	Gold
Qmax (with case temperature control option):	10 Watts
Laser Diode Driver & TEC Interface Connector:	15 Pin d-Sub
Dimensions:	60mm x 64mm x 53mm

PIN CONFIGURATION MODEL LDM-BUTTERFLY-0 (MOST COMMON)

Laser Diode Anode:	Pins 9,10
Laser Diode Cathode:	Pins 11,12
TE Cooler (+):	Pin 1
TE Cooler (-):	Pin 14
10K Thermistor:	Pins 2,5

Refer to Pin Configuration Image

PIN CONFIGURATION MODEL LDM-BUTTERFLY-1

Laser Diode Anode:	Pins 11,13
Laser Diode Cathode:	Pins 3,12
TE Cooler (+):	Pin 1,6
TE Cooler (-):	Pin 7
10K Thermistor:	Pin 2

Refer to Pin Configuration Image

PIN CONFIGURATION MODEL LDM-BUTTERFLY-2

Laser Diode Anode:	Pin 10
Laser Diode Cathode:	Pin 11
TE Cooler (+):	Pin 1
TE Cooler (-):	Pin 14
10K Thermistor:	Pins 2,5

Refer to Pin Configuration Image Above

LDM-BUTTERFLY-X SPECIFICATIONS

PIN CONFIGURATION MODEL LDM-BUTTERFLY-EAGLEYARD

Laser Diode Anode:	Pin 10
Laser Diode Cathode:	Pin 11
PD (-):	8
PD (+):	9
Refer to Pin Configuration Image Above	

CASE TEMPERATURE CONTROL OPTION (CASE-COOLER)

Includes Additional Peltier Cooler Embedded Under Laser Diode Mounting Pad	
Includes Micro-Fan Heat Removal from Mount Base	
Micro-Fan Requires 12 VDC (85mA)	
Qmax with CASE-COOLER = 10 Watts	
TEC Current Max is 5 Amps	
Order Code: CASE-COOLER	
Order Code Example: LDM-BUTTERFLY-0-CASE-COOLER	

DATA SHEET

PIN CONFIGURATIONS

	Order Code 0	Order Code 1	Order Code 2	Order Code Eagleyard
1	TEC+	TEC+	TEC+	n.c.
2	NTC	NTC	NTC	n.c.
3	PHD-	CAT	PHD+	n.c.
4	PHD+	PHD+	PHD-	n.c.
5	NTC	PHD-	NTC	n.c.
6	n.c.	TEC+	PHD-	n.c.
7	n.c.	TEC-	PHD+	n.c.
8	n.c.	n.c.	n.c.	PHD-
9	ANO	n.c.	CAT	PHD+
10	ANO	n.c.	ANO	ANO
11	CAT	ANO	CAT	KAT
12	CAT	CAT	n.c.	n.c.
13	n.c.	ANO	n.c.	CASE
14	TEC-	n.c.	TEC-	n.c.

CONNECTOR

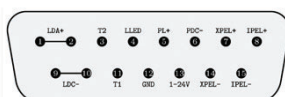

SubD-15 male

PinNo.	abbr.	function
1; 2	LDA+	Laser diode Anode (+)
9; 10	LDC-	Laser diode Cathode (-)
4	LEDA+	LaserON-LED-Anode (+) ca. 5mA (vs. GND)
5	PL+	Pilot laser (+) (PL- at Pin GND)
6	PDC-	Photo diode Kathode (-) (Anode at GND)
8	IPEL+	TEC (+) internal Butterfly TEC
15	IPEL-	TEC (-) internal Butterfly TEC
3	2TSEN	2nd external Temperature sensor Input; default NTC10kOhm (vs. GND)
11	1TSEN	1st internal Temperature sensor Input; default NTC10kOhm (vs. GND)
12	GND	Common Ground - n.c. to screen !
13	+24V	1.2V..24V Supply for fan etc., max. 300mA (vs. GND)
7	XPEL+	TEC (+) external TEC (only Type 636 and 704)
14	XPEL-	TEC (-) external TEC (only Type 636 and 704)



DIMENSIONS (mm)

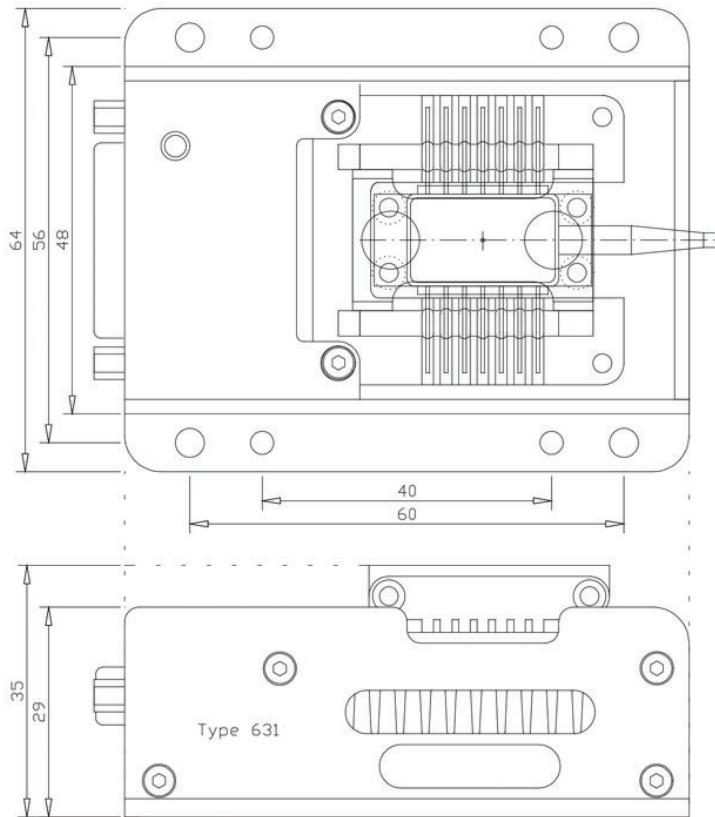

Product Warranty:

In addition to the standard full one year warranty, this product is offered with an additional 3 months of extended warranty for a total of 15 months of warranty coverage. The warranty includes all parts and labor. The warranty does not include customer induced product damage.

Our Customer Commitment:



You Get Direct, Fast Tech-Support from a Product ENGINEER ... Not a Sales Person

You get DIRECT access to the correct factory engineer for your product. We eliminate the sales person "middle-man" back and forth time delays resolving technical issues. No more "Contact Us" forms. Every product has an assigned engineer in our auto-messaging data base to give you direct, immediate access to the correct tech-support info.



You Get an Extended Warranty

All products from Laser Lab Source come with a 12 month factory warranty. Additionally, we offer and extra 3 months of warranty on top of the standard warranty. Warranty does not include customer induced product damage.



You Get the Lowest Factory-Direct Prices Worldwide

All of our 3rd party global suppliers set & quote their own direct pricing. There are NO Mark-Up's. You get their lowest direct price.