

## LASER DIODE CONTROL ELECTRONICS MODULE – SF6030

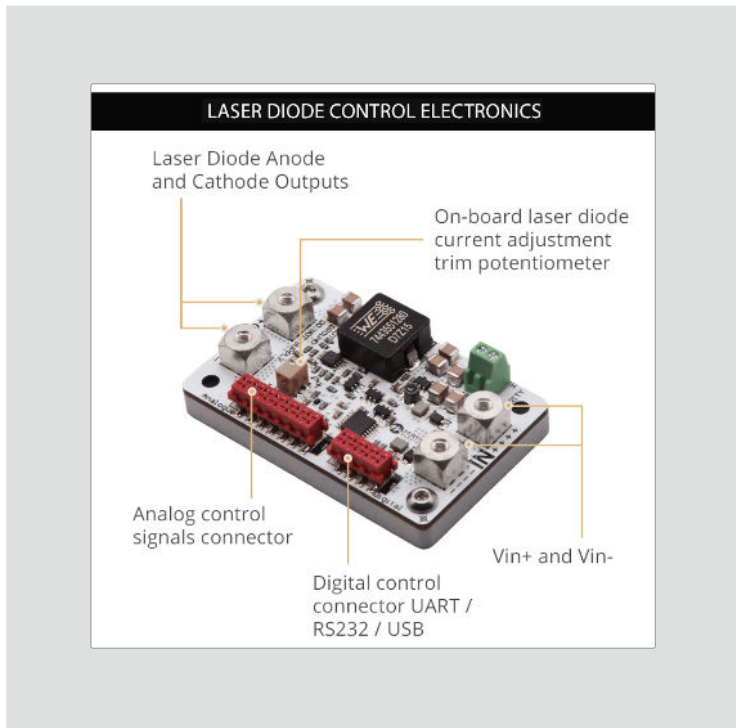

## LASER DIODE DRIVER MODULE

- ◇ Up to 30 Amp Output Current
- ◇ Up to 10 V Compliance Voltage
- ◇ Soft-Start Current Ramp, Current Limit, Reverse Voltage Protection
- ◇ NTC Thermistor Input for Laser Over-Temperature Fast Shut-Down
- ◇ GUI Control Software Included

Semiconductor Laser Sources and Control Instruments



Laser  
Diode  
Controllers



## ALL-ENCOMPASSING PROTECTION FOR YOUR LASER DIODE

### **On-Board Component Level Protection Against Input Power Surges and Reverse Voltage Transients:**

An integrated on-board zener diode in parallel with the bias current path protects the laser diode from damage which can occur from reverse voltage transients. These transients can occur when a standard DC power supply source is momentarily interrupted due to a black-out or brown-out power outage.

### **Additional External Over-Temperature Monitor/ Shut-Down Input:**

Primarily designed for integration of the module into a laser system, an additional thermistor input is provided to allow the user to monitor the temperature from an external measurement point. This can then be used to shut off the laser diode if the temperature limits for the laser are exceeded.

### **Soft-Start Current Ramp:**

There is an internal 500 millisecond soft-start ramp to the current set-point. This reduces the potential for thermal shock to the laser at power ON and is used to ensure good electrical contact prior to fully applying the current bias the laser diode.

### **Controller Over-Temperature Protection:**

The controller module includes an on-board sensor to prevent over-temperature operation of the controller. The controller issues a warning if the temperature exceeds 60°C, and shuts down the laser driver if the temperature exceeds 80°C. Operation resumes when the temperature falls below 58°C.



### **Advanced Performance Laser Diode Control Module**

These high performance OEM laser diode drivers are used extensively in demanding industrial laser applications. The SF6xxx series of CW drivers are used for laser marking, welding, soldering, and cutting applications. They are also used in medical equipment and laser measurement equipment such as spectrometers, LIDAR and range finders.

In addition to high reliability and small form factor components, the SF6xxx series CW drivers offer multiple levels of protection for high power single and multi-emitter lasers. A soft-start ramp to the drive current setpoint reduces thermal shock to the laser. Other key protection features include a user adjustable driver current limit, over-current protection, over-temperature protection and protection against reverse current transients.

### **Sourcing Current to your Laser and the Crowbar Clamp Protection**

The modules are initially enabled by applying an active high 3.3V ~ 5V DC compatible logic input signal. The driver sources current and begins to operate when the 5V input enable pin is high. To ensure that the current enable is applied without overshoot, a slow start sequence initiates when the enable pin is set high. The enable pin can also be used in the quasi-CW mode. The output current is set by applying an analog signal to the current set pin on the control connector. The current set pin can be used for analog modulation by applying sign wave, square wave or ramp signal. The output may be pulsed by applying a TTL square signal to enable pin. The minimum pulse duration 500 microseconds.

These high power drivers offer a highly reliable crowbar clamp to short the current and disable power to your laser diode. There is a pin on the control connector which shows the crowbar protection circuit status. The crowbar will short the output while the module is in an over-current shutdown or an over-temperature shutdown mode.

### **Driver Safety Interlock, Current Monitoring and Voltage Monitoring**

The SF6xxx controllers have an interlock pin which must be connected to the ground order for output current to be enabled. The safety interlock is used to shut-down the module with a logic high signal triggered by an external interlock trigger such as a door to the lab or an external over-temperature circuit. These modules also have an on-board temperature sensor which will shut-down the output when the temperature exceeds a pre-set temperature. The output voltage of the driver can be monitored by a linear scaled voltage monitor output, 0~1V. The voltage is measured between LD+ terminal and GND. The current can be monitored by a linear voltage output.

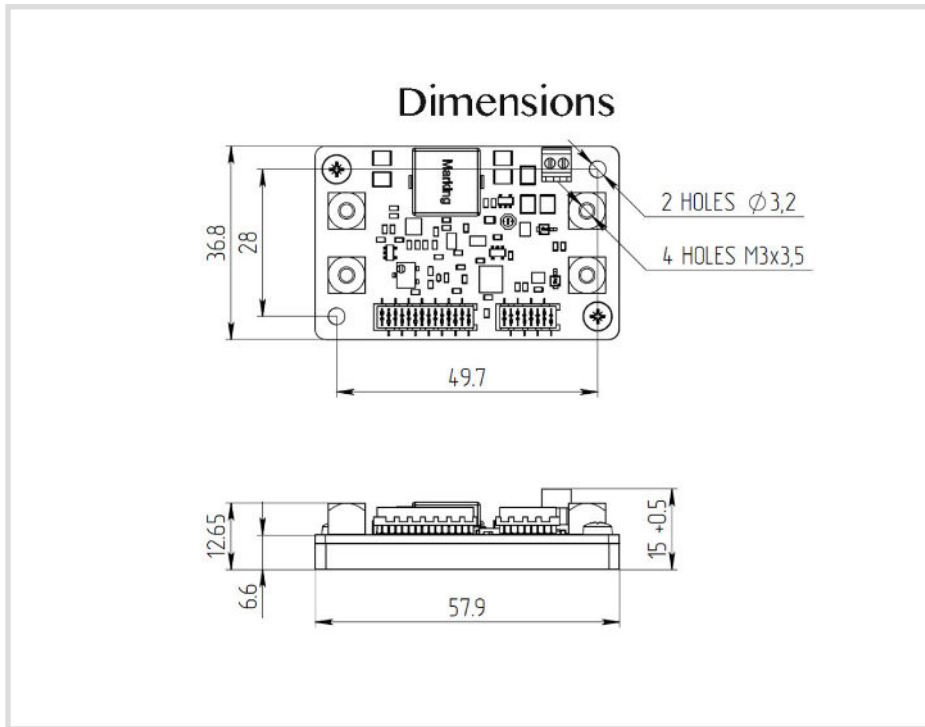

Product includes control software GUI for simple set-up and monitoring of your laser diode; alternately - you can use the trim pots on the board or the analog control connector



Software opens when you connect the USB adapter board; USB adapter board is included with shipment



## Rise time

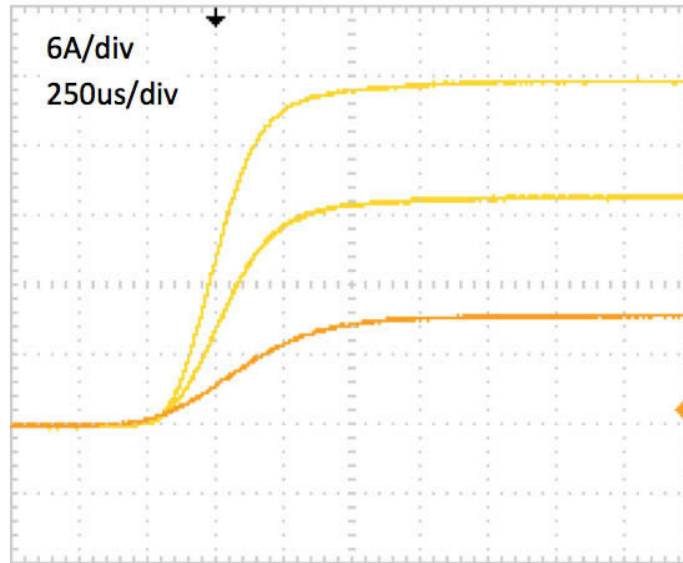

Recommended Switching Power Supply  
Mean Well RSP-320-12 \*



\* Can be purchased with the Laser Diode Controller



## SF6030 SPECIFICATIONS

### LASER DIODE CURRENT & VOLTAGE

- Output Current Range (I): 1-30 Amps
- Output Voltage Range (V): 0-10 Volts
- Setpoint : 0.01 Amps
- Rise Time: (Iout = 15A) min - 300 $\mu$ s; max - 700 $\mu$ s
- Rise Time: (Iout = 30A) min - 300 $\mu$ s; max - 600 $\mu$ s
- Fall Time: min - 300 $\mu$ s; max - 1500 $\mu$ s
- Current Stability: <0.2 %
- Current Setpoint Absolute Accuracy: <1 %

### LASER DIODE PROTECTION

- Soft-Start Ramp to Current Setpoint
- User Adjustable Current Limit
- Over-Current Protection Fast Shutdown
- Over-Temperature Thermal Warning and Shutdown
- Reverse Current Protection
- Crowbar Circuit Protection
- Disable Input
- Interlock

### DIMENSIONS AND WEIGHT

- Dimensions: 37 mm x 58 mm x 30 mm
- Weight: 55 g

### USER INTERFACE

- Analog
- RS232/UART Digital Interface
- USB Optional: \$25.00 (Option UART-USB)
- Enable / Disable Input Signal Input
- User Adjustable Trim Potentiometer Current Limit

### DRIVER INPUT

- Input Voltage Range (Vin): 10V to 14V
- Recommended Switching Power Supply: Mean Well RSP-320-12, available for purchase with this laser diode controller.

### PACKAGE SET

- Driver – 1 pcs
- 50 cm ribbon cable with one 8-pin connector – 1 pcs
- 50 cm ribbon cable with one 14-pin connector – 1 pcs
- Wires fixing set – 1 pcs
- Datasheet & User Manual – 1 pcs

### WARRANTY PERIOD

- 1-year manufacturer's warranty



**PRODUCT WARRANTY:**

This product is sold with a full one year warranty. The warranty includes all parts and labor. It is warranted to be free from defects in material and workmanship for a period of one year from the date of shipment. The warranty does not include damage to the product due to customer mishandling or use of the product outside of its specified maximum ratings.

**INSTALLATION SUPPORT OR TECHNICAL SUPPORT FOR THIS PRODUCT:**

**800-887-5065 extension 1**  
**[contact@laserdiodesource.com](mailto:contact@laserdiodesource.com)**



**LASER DIODE**  
TECHNOLOGIES

Part of the Laser Lab Source Group:

[LaserLabSource.com](http://LaserLabSource.com)

[LaserDiodeSource.com](http://LaserDiodeSource.com)

[LaserDiodeControl.com](http://LaserDiodeControl.com)

Laser Diode Technologies

Laser Lab Source Inc.

1820 W. Lincoln Street

Bozeman, MT USA 59715

[contact@LaserDiodeSource.com](mailto:contact@LaserDiodeSource.com)

[contact@LaserDiodeControl.com](mailto:contact@LaserDiodeControl.com)

800-887-5065

800-887-5065