

680nm Laser Diode, 800mW Output Power, Fiber-Coupled HHL Package

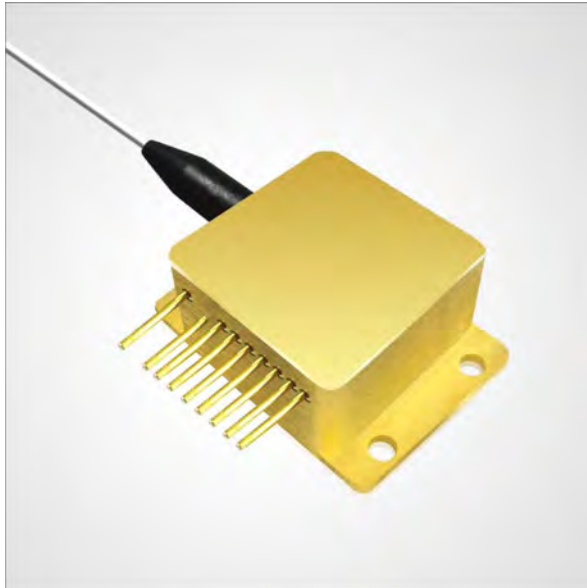

Features

- 680nm, 800mW Output
- 105 μ m Multimode Fiber, NA 0.22
- FC/APC Fiber Connector
- 9-Pin High Heat Load Package
- Integrated TEC, Thermistor, and Photodiode

LASER LAB SOURCE

World Leading Products for **Laser Scientists & Engineers**

680NM-800MW Overview

This Fabry-Perot laser is offered in an industry-standard 9-pin HHL laser package, and includes integrated photodiode, thermoelectric cooler, and thermistor.

This laser is provided with 105µm multimode fiber, NA 0.22, and terminated with an FC/APC connector. Other options are available; inquire for options and details.

Proven Laser Diode Expertise

These high stability fiber coupled laser diodes are designed and manufactured to meet the most demanding R&D and industrial applications.

Proprietary design, packaging, and fiber coupling processes produce laser diodes with very high stability and low noise. Each laser diode is subject to extensive testing and burn-in before shipment to ensure the highest possible levels of quality and long term reliability.

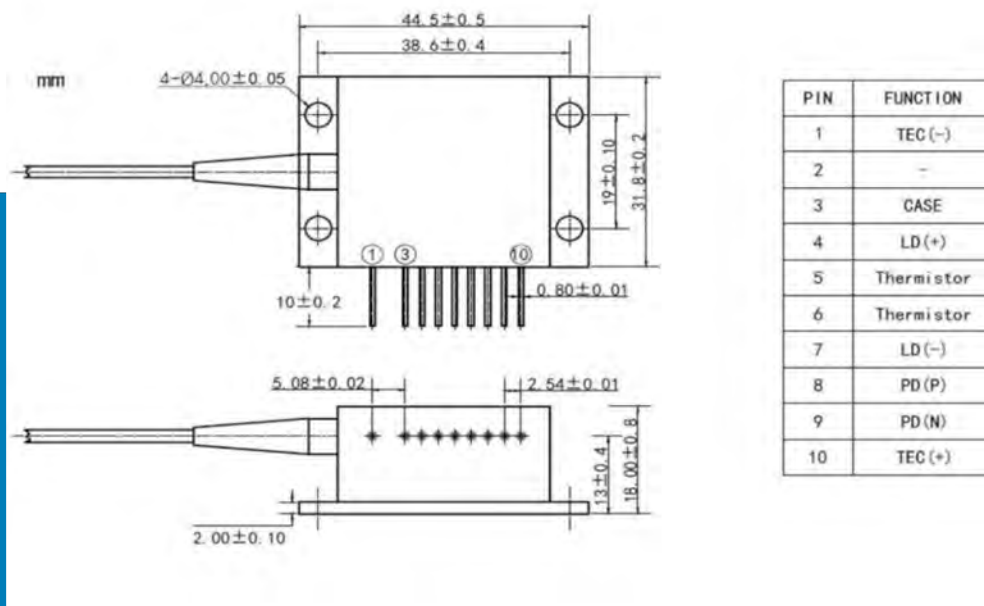



OPTICAL SPECIFICATIONS AT 25°C

- Center Wavelength: 680 nm \pm 10 nm
- Output Power: 800 mW
- Wavelength Temperature Coefficient: 0.2 nm/°C
- Spectral Width (FWHM): 2.0 nm

ELECTRICAL SPECIFICATIONS AT 25°C

- Operating Current: 1.3 A
- Threshold Current: 0.4 A
- Operating Voltage: 2.4 V
- TEC Current: 6 A (max)
- TEC Voltage: 9.8 V (max)

PACKAGE AND FIBER SPECIFICATIONS

- 9-Pin High Heat Load Package
- Integrated Photodiode, TEC, and Thermistor
- Fiber Type: Multimode
- Fiber Core Diameter: 105 μ m
- Fiber NA: 0.22
- FC/APC Connector Termination

WORLD LEADING PRODUCTS
FOR LASER SCIENTISTS AND ENGINEERS