



## 830nm, 50mW Coaxial Laser Diode SMF Fiber with FC/PC Connector



### PN: RLS/830NM-50MW-SMF

- Wavelength: 830 nm
- Output Power: 50 mW
- Includes Integrated Photodiode
- Single-Mode Fiber, 5  $\mu$ m Core
- Standard FC/PC Connector (Inquire for other connector options)

**LASER LAB SOURCE**

World Leading Products for  
Laser Scientists and Engineers



## 830NM-50MW-SMF Product Overview

This Fabry-Perot laser is offered in a coaxial single-mode fiber-coupled package, with integrated photodiode. The laser is mounted in a heat-sink bracket that allows for multiple mounting options.

This laser is coupled to 5  $\mu\text{m}$  single-mode fiber, NA 0.12, and terminated with an FC/PC connector. (Other options are available; inquire for options and details)

## Proven Laser Diode Expertise

These high stability fiber coupled laser diodes are designed and manufactured to meet the most demanding R&D and industrial applications.

Proprietary design, packaging, and fiber coupling processes produce laser diodes with very high stability and low noise. Each laser diode is subject to extensive testing and burn-in before shipment to ensure the highest possible levels of quality and long term reliability.

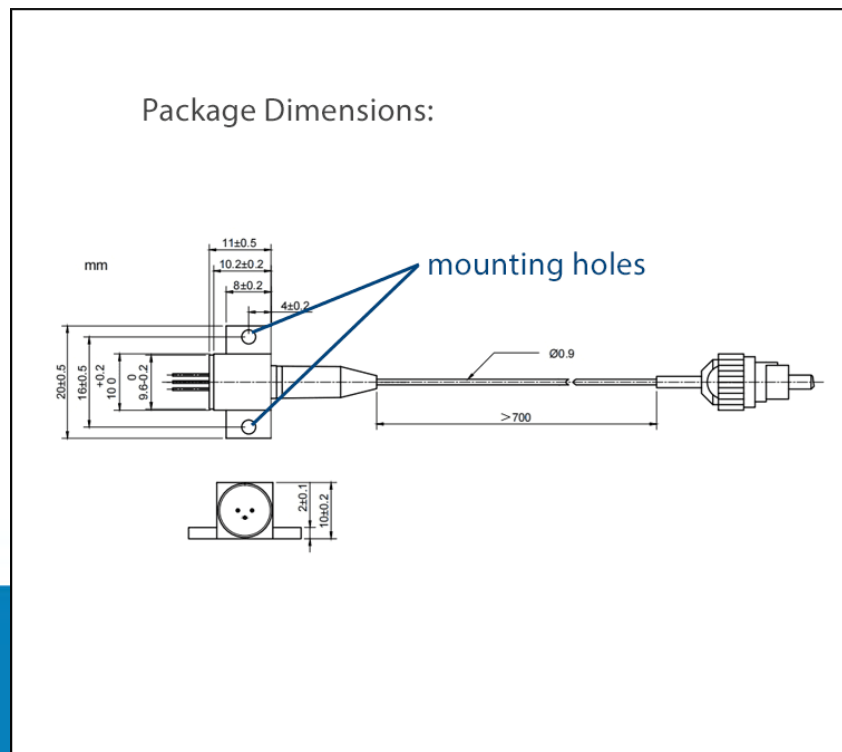



## OPTICAL SPECIFICATIONS

- Output Wavelength: 830 nm  $\pm$ 15 nm
- Output Power: 50 mW
- Spectral Width (FWHM): 2.0 nm
- Wavelength Temp. Coefficient: 0.3 nm/ $^{\circ}$ C
- Beam Type: Gaussian Beam
- Laser Type: Fabry-Perot
- Includes Integrated Photodiode
- PD Current: 0.3 mA

## FIBER SPECIFICATIONS

- Fiber Type: Single Mode Fiber
- Fiber Core: 5  $\mu$ m
- N.A.: 0.12
- Fiber Length: >80 cm
- Fiber Connector: FC/PC (Other Types Available; Inquire)

## ELECTRICAL SPECIFICATIONS

- Threshold Current: 30 mA (typ)
- Operating Current: 200 mA (typ)
- Operating Voltage: 2.3 V (typ)



**LASER LAB SOURCE**

world leading products for **Scientists & Engineers**

manufactured by

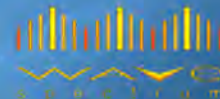

**PRODUCT SALES AND SERVICE:**

Orders for this product are fulfilled by Laser Lab Source in North America.

**PRODUCT WARRANTY:**

This product is sold with a full one year warranty. It is warranted to be free from defects in material and/or workmanship for a period of one year from the date of shipment. Warranty does not include customer induced damage to the product through mishandling.



Laser Lab Source, a division of Research Lab Source Inc.  
670 S. Ferguson St., Suite 3  
Bozeman, MT 59718 USA

Phone: 800-887-5065

[www.LaserLabSource.com](http://www.LaserLabSource.com)