



User Manual

User Manual
RGB Photonics GmbH
Lambda mini Evo
Version: 2.1.0
Date: October 06, 2016

This document is protected by copyright. Do not copy or publish this document or parts of it without written permission of RGB Photonics GmbH.

Product specifications and descriptions in this manual are subject to change without notice. RGB Photonics GmbH will not be responsible for errors and omissions in this manual or for direct or incidental damages in connection with the use of this device or information.

© 2016 RGB Photonics GmbH
Donaupark 13
93309 Kelheim
Germany

Telephone: +49 9441 1750 33-0
Website: <http://www.rgb-photonics.com>
E-Mail: sales@rgb-photonics.com

Contents

1	Laser Safety Precautions.....	1
2	Introduction	2
2.1	Product Overview.....	2
2.2	Package Contents.....	3
3	Installation and Operation.....	4
3.1	Precautions.....	4
3.2	Laser operation.....	4
3.3	Troubleshooting.....	5
4	Computer Control.....	7
4.1	Ltune Laser Control Software.....	7
4.2	Serial Communication.....	8
5	Specifications.....	12
5.1	General Specifications.....	12
5.2	Beam Specifications.....	12
5.3	Electrical Specifications.....	12
5.4	Mechanical specifications.....	13
6	Certifications and Compliance.....	14
7	Appendix.....	17
7.1	List of abbreviations.....	17

1 Laser Safety Precautions



CAUTION: This device emits visible and invisible LASER radiation. Avoid exposure to the beam!

Lasers emit visible and invisible radiation that may cause damages to material and person, mainly by thermal effect. Radiation entering the human eye can damage the retina, which leads to partial or total loss of vision. The damage can occur without particular perception or sensation of pain.

Please consider all protection and safety regulations while handling laser systems. Always use laser protection glasses for the specified wavelength range.

Never direct the laser towards people. Keep the laser beam away from reflective surfaces in order to avoid uncontrolled reflections. Do not mount the laser at eye level.

It is your responsibility to guarantee the laser safety as required by law. Please pay attention to safety regulations DIN EN 61010-1, DIN EN 60825-1:2003-10 and DIN EN 60950 when operating the laser.

The Lambda mini series is specified by the United States National Center for Device and Radiological Health (CDRH) as a class 3b laser product. Visible and invisible laser radiation is emitted.

Modifications that may affect any aspect of the product's performance or intended functions will require re-certification and re-identification of the product in accordance with the provisions of 21CFR 1040.10 and 1040.11.

Lambda mini laser modules are marked with a warning label as show on the right.



2 Introduction

2.1 Product Overview

The Lambda mini series is currently the world's smallest complete laser module. In a remarkably small design, it includes not only the laser diode and precision collimating optics, but also the laser controller and power supply via USB. All that is needed for operating and controlling the laser is a simple USB cable connected to a PC. Its compact size makes the Lambda mini an ideal choice as a precision light source for space-limited application. The Lambda mini Evo emits a free collimated TEM₀₀ laser beam. Also available is the Lambda mini Fiber, which couples the laser beam into an optical fiber.

Features

- Remarkably small design
- Optical output powers up to 100 mW
- Powered by USB (no extra power adapter or cable required)
- Horizontal and vertical mounting options for various rail systems
- Produced in clean-room atmosphere
- Temperature monitoring
- Professional housing
- USB interface
- Ltune laser control software included
- Excellent value for money

2.2 Package Contents

Laser module

In order to provide the best beam quality only high quality optical components are used within the laser module.



Cable

A standard Mini USB cable is used for connecting the laser to a computer or power supply. The length of the cable is 1.5 m (5 ft).

Software

The CD-ROM includes the Windows application software Ltune for configuring and controlling the laser system as well as this manual as a PDF file.

3 Installation and Operation

3.1 Precautions

- **Take care of all laser safety instructions** as described in chapter 1. Always wear laser protection glasses for the specified wavelength range.
- Consider regulations for Electrostatic Discharge (ESD).
- Do not open the laser head. Opening the case voids the warranty and may cause uncontrolled laser radiation.
- Always mount the laser module securely and pay attention to sufficient heat dissipation.
- **Do not reflect the laser beam back into the laser head.** The laser diode could be damaged if more than 2 % of the emitted power is reflected back into it. Carefully check all mirroring surfaces of your optical setup for possible back reflections. If required, use a suitable optical insulator.
- Do not exceed the environment conditions specified in chapter 5.



3.2 Laser operation



The Lambda mini Evo laser module is controlled via USB and operated in constant CW mode without an external control voltage.

1. In order to set up the laser module for operation, please:
2. Install the Ltune laser control software including the device driver on a Windows PC.
3. Connect the Lambda mini laser module to the computer using the supplied USB cable. You can also use any other standard Mini USB cable.
4. After a quick self-test the green POWER LED should be lit continuously.
5. Start the Ltune application on the computer. The laser module should be detected and initialized automatically.
6. Make sure the interlock connector is closed.
7. In Ltune, set the desired output power and click on the power on/off button. The laser will start with a 5 second delay (as required by laser safety regulations). Once the laser is active, the EMISSION indicator is lit.

The laser can be switched off remotely from the computer or by simply disconnecting the USB cable.

Status Indicators

The laser module includes two LEDs to indicate the laser status:

LED	Status	Description
POWER 	On	Power supply connected, self-test successful
	Off	Power supply not connected
	Flashing	Error
EMISSION 	On	Laser active, emission possible (depending on selected output power)
	Off	Laser inactive
	Flashing	5 second delay before activating laser

Interlock

The interlock connector next to the USB port on the device can be used to enable or disable laser emission. You can either use the supplied jumper to close the contacts or attach a custom switch. If the two pins are not connected, the laser is turned off and no emission is possible. When the two pins are connected again, the laser emissions starts after a 5 second delay, if the laser is remotely turned on and an emission power larger than zero is selected.

3.3 Troubleshooting

If the device is detected by Ltune, but there is no laser emission:

Please make sure that these conditions are met:

- The green LED is lit continuously (if not, please check the bottom of the Ltune window for error messages).
- The interlock connector is closed.
- The power on/off button in Ltune is turned on
- An output power larger than zero is selected.

If the device is not detected when Ltune is started:

First of all, please disconnect the laser from the computer, restart the computer, connect the laser again and start the Ltune software.

If the laser is still not found: The Ltune software communicates with the laser using a "virtual serial port". If the driver is installed correctly, it should show up in the Windows Device Manager. You can open the device manager by clicking Start -> Control Panel (-> Performance and Maintenance)-> System-> Hardware-> Device Manager.

In the device manager, please open the "Ports (COM & LPT)" subtree. One of the COM ports listed there should belong to your laser. If you right-click on the correct item, choose "Properties" and then the "Driver" tab page, it should read: "Driver Provider: FTDI" and "Driver Version: 2.8.14.0" (or later). If this is the case, please start Ltune and try to select this COM port manually by unchecking "Auto-scan all serial ports" in "Device setup".

If your laser is not listed in the device manager or marked with an exclamation or question mark, please try the following:

1. Disconnect your laser from the computer and from power supply.
2. Download <http://www.ftdichip.com/Resources/Utilities/FTClean.zip> and run this tool to remove the FTDI driver from your computer.
3. Reinstall Ltune from the CD.
4. Reconnect the laser to the computer.
5. Start Ltune.

4 Computer Control

The Lambda mini uses a USB interface for remote control. The laser can be controlled with

- The Windows application software Ltune (included) or
- Custom user software via serial communication.

4.1 Ltune Laser Control Software

The Lambda mini laser can be configured and controlled using the Ltune software for Windows. The software features:

- Output power adjustment
- Display of the laser status, configuration and operating hours
- Temperature display



To install the software, simply run the setup file from the CD-ROM included in the package. The setup package then installs the application software and the device driver. For the operating system to properly recognize the device, it's best if you install the software first before attaching the device.

The software is tested with 32 and 64 bit versions of Windows 8, 7, Vista and XP. It requires the Microsoft .NET framework version 3.5 or 4.0, which is already installed on most PCs. If this framework is not installed, the setup package asks you to install it first. You can find the setup file for the .NET framework on the CD or download it from Microsoft's website. Please note that you need at least version 3.5 of the .NET framework.

After the software is installed, please connect your Lambda minilaser to a USB 2.0 port on the computer. You can use the provided USB cable or almost any other Mini-USB cable.

If not already installed wait until the laser driver is completely installed. The laser should be detected automatically. If not you can click on device setup to start a new search.

Please note that you can change the user interface to a more compact view by clicking the small button next to "Device properties".

Please also note that the Ltune software works with different laser modules and therefore provides support for some features that are not included in the Lambda mini Evo.

4.2 Serial Communication

Overview

When the laser controller is connected to a PC and the device driver installed, it shows up as a virtual COM port and can be accessed from almost any programming language. A detailed description of the commands and queries is given in the following section.

The command settings are not stored when the system is powered down.

Communication protocol

The commands and queries have the following syntax:

Commands: command=<parameter value>

A command changes an actual setting. The syntax is the command, followed by an equal sign and the parameter value. The parameter value is the value to be set. Commands have no return value.

Queries: query?

A query returns information about the device or the value of a setting. The syntax is the query, followed by a question mark. Queries have no parameter value. A query delivers a return value.

Return Code

A return code gives information about the processing of a command or query. There is always a space character between the return code and the result. The return codes are:

Code	Name	Description
0	COMMAND_SUCCESS	Command successful
1	COMMAND_INVALID	Command invalid
2	PARAMETER_ERROR	Wrong numbers of parameters
3	VALUE_INVALID	Parameter value is out of range
4	CODE_INVALID	Unlocking code is wrong
5	DEVICE_LOCKED	Device is locked for this command
6	FUNCTION_NOT_SUPPORTED	This function is not supported
7	COM_TIME_OUT	Timeout while reading command (60 s)
8	VALUE_NOT_AVAILABLE	This value is currently not available

All commands and queries and all responses from the device are followed by the line termination string “\r\n” (carriage return & line feed). All instructions have to be written in capital letters.

Initializing the serial communication

The Lambda mini uses following communication settings:

Baud rate	57600
Parity	None
Data bits	8
Stop bits	1

Turning the laser on and off

This command is used to set and read the “Laser Enable” request. The laser can only be activated if the key switch is in the ON position and the interlock is closed.

Command/ Query	Parameter value	Return code	Return value
0=	0: Delete EnableRequest 1: Set Enable Request	COMMAND_SUCCESS PARAMETER_ERROR	-
0?	-	COMMAND_SUCCESS	0: Enable Request not set 1: Enable Request set

Temperature settings

The Lambda mini Evo monitors the operating temperature. If it exceeds the permitted temperature range, the laser is turned off to prevent damage to the module.

Command/ Query	Parameter value	Return code	Return value
T?	-	COMMAND_SUCCESS VALUE_NOT_AVAILABLE	Current temperature in °C
LTN?	-	COMMAND_SUCCESS	Lowest operating temperature in °C
LTP?	-	COMMAND_SUCCESS	Highest operating temperature in °C

CW mode

The Lambda mini laser is operated in CW mode at constant power between 0 and 100 % of the maximum output power.

Command/ Query	Parameter value	Return code	Return value
P?	-	COMMAND_SUCCESS	Output power in mW
P=	Output power in mW (value between 0 and LP)	COMMAND_SUCCESS VALUE_INVALID	-
LP?	-	COMMAND_SUCCESS	Maximum output power in mW

Status and device information

The query S? gets the actual status of the laser system including information about the Enable Request, the interlock and active errors.

The query R? returns the operation hours of the laser system. The operation time is the accumulated time during which the laser was active (red LED on).

Query	Parameter value	Return code	Return value
S?	-	COMMAND_SUCCESS	Current device status (see table below)
R?	-	COMMAND_SUCCESS	Total operating hours [hhhh:mm]
DM?	-	COMMAND_SUCCESS	Manufacturer
DT?	-	COMMAND_SUCCESS	Device name
DS?	-	COMMAND_SUCCESS	Serial number
DO?	-	COMMAND_SUCCESS	Software version
DW?	-	COMMAND_SUCCESS	Emission wavelength in nm
DF?	-	COMMAND_SUCCESS	Available features (reserved for future use)
DC?	-	COMMAND_SUCCESS	ACC = Active current control APC = Active power control

The result of the status request S? is a bit-wise combination of the following values:

Code	Mnemonic	Description
0x01	LASER_ON	Laser system in active, radiation can be emitted
0x02		(reserved)
0x04	INTERLOCK_OPEN	The interlock is open
0x08	ERROR	Error is active (error can be read with E? query)
0x10	TEMPERATURE_OK	Temperature of laser head is ok

Error status of the laser system

The query E? reads the actual active errors of the laser system.

Query	Parameter value	Return code	Return value
E?	-	COMMAND_SUCCESS	Error code (see table below)

Possible error codes:

Code	Mnemonic	Description
0x01	LASER_HEAD_OVERTEMP	Temperature of laser head is too high
0x02	LASER_HEAD_UNDERTEMP	Temperature of laser head is too low
0x04	TEMP_SENSOR_OPEN	Temperature-sensor connection is broken
0x08	TEMP_SENSOR_SHORTENED	Temperature sensor cable is shortened
0x40	LASER_OVERCURRENT	Current for laser head is too high
0x80	FATAL_INTERNAL_ERROR	Internal error (laser system cannot be activated)

5 Specifications

5.1 General Specifications

Noise:	< 2 % RMS
Power stability:	< 2 % (10 h)
Warm-up time:	5 sec
Drive mode:	Active current control (ACC)
Control mode:	Constant power, controlled via USB
CDRH Classification:	Class 3b
Weight:	40 g
ESD protection:	Level 4
Operating temperature:	0 °C to 45 °C (non-condensing)
Storage temperature:	-25 °C to 70 °C

5.2 Beam Specifications

Beam diameter:	1.1 × 2.2 to 1.2 × 2.8 mm (depending on wavelength)
Divergence:	< 0.9 mrad
Spatial beam mode:	TEM ₀₀
Polarization:	> 100:1 linear
Polarization angle:	vertical
Beam alignment:	< 5 mrad and < 0.1 mm (compared to base mount)
Pointing stability (10 h):	< 5 μrad/K

5.3 Electrical Specifications

Supply voltage:	5 V, powered via USB
Supply current:	up to 500 mA

5.4 Mechanical specifications

Length: 40.0 mm (1.57")

Width: 25.0 mm (0.98")

Height: 25.0 mm (0.98")

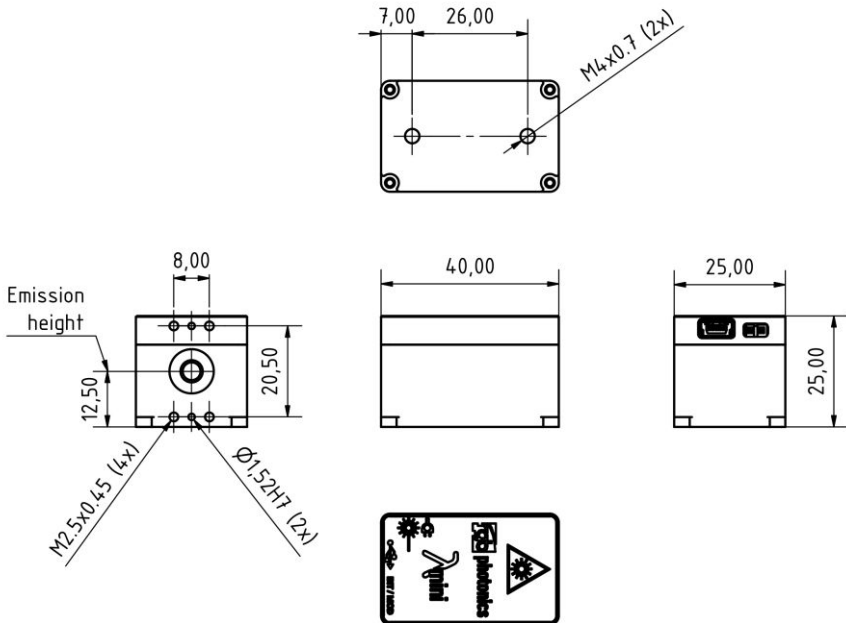

All dimensions in mm.

3D CAD files are available for download on www.rgb-photonics.com.

6 Certifications and Compliance

CE Declaration of Conformity

The manufacturer

RGB Photonics GmbH
Donaupark 13
93309 Kelheim



declares that the following products

Lambda mini Evo	Version 1.0
Lambda mini Fiber	Version 1.0

comply with the following normative documents

EN55022: 2010
EN61000-6-2: 2005

and therefore with the following EG requirements

Electromagnetic compatibility (2014/30/EU)

This declaration applies to all models of the above named product versions, in case they will be used in the configuration of the test assembly.

Kelheim, 06.10.2016

Mathias Reichl

FCC Compliance

This declaration applies to the following products:

Lambda mini Evo	Version 1.0
Lambda mini Fiber	Version 1.0

This device complies with part 15 of the FCC Rules. Operation is subject to the following two conditions: (1) This device may not cause harmful interference, and (2) this device must accept any interference received, including interference that may cause undesired operation.

This equipment has been tested and found to comply with the limits for a Class A digital device, pursuant to Part 15 of the FCC Rules. These limits are designed to provide reasonable protection against harmful interference when the equipment is operated in a commercial environment. This equipment generates, uses and can radiate radio frequency energy and, if not installed and used in accordance with the instruction manual, may cause harmful interference to radio communications. Operation of this equipment in a residential area is likely to cause harmful interference in which case the user will be required to correct the interference at his own expense.

RoHS Declaration of Conformity

The manufacturer

RGB Photonics GmbH
Donaupark 13
93309 Kelheim

declares that the following products

Lambda mini Evo	Version 1.0
Lambda mini Fiber	Version 1.0

contain no toxic substances which are specified in the

RoHS Directive 2011/65/EU.

The conformity to RoHS Directive 2002/95/EG is confirmed.

This declaration applies to all models of the above named product versions.

Kelheim, 06.10.2016

Mathias Reichl

7 Appendix

7.1 List of abbreviations

°C	Degrees centigrade
°F	Degrees Fahrenheit
µm	Microns
µrad	Micro radiant
AC	Alternating current
A	Ampère
BNC	BNC connector
CDRH	Center of Device and Radiological Health
CE	Conformité Européenne
CW	Continuous wave
DC	Direct current
D-SUB9	D-SUB9 connector
ESD	Electrostatic discharge
Hz	Hertz
in	inch
K	Kelvin
kHz	Kilohertz
LED	Light emitting diode
m	meters
MHz	Megahertz
mm	Millimeter
mrad	Milliradiant
nm	Nanometer
RMS	Root mean square
RoHS	Restriction of the use of certain hazardous substances
sec	seconds
TEC	Thermo electric cooler
TEM	Transverse electromagnetic mode
TTL	Transistor-transistor logic
V	Volts
VAC	Volts, alternating current
VDC	Volts, direct current
W	Watt
WEEE	Waste Electrical and Electronic Equipment