

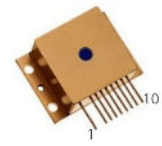

PRODUCT DATA SHEET

Laser Diode (HHL w/window package)

Model FB-M1450-1500HO



- 1-TEC (-)
- 2-
- 3-
- 4- Laser Anode(+)
- 5- Thermistor (2)
- 6- Thermistor (1)
- 7- Laser Cathode (-)
- 8- PD Anode (+)
- 9- PD Cathode (-)
- 10- TEC (+)

Specification	Symbol	Typical	Unit
Laser Emitter			
Peak Wavelength	λ_{op}	1450±20	nm
CW Optical Output Power	P_{op}	1.5	W
Operation Current	I_{op}	<4.5	A
Operation Voltage	U_{ld}	1.1±0.1	V
Threshold Current	I_{th}	< 0.9	A
Beam Divergence (FWHM)	$\theta_{ }$	16±3	degree
Beam Divergence (FWHM)	θ_{\perp}	1±0.3	degree
Spectrum Half-Width (FWHM)	$\Delta\lambda$	<7	nm
Emitting Area	$W \times d$	100x1	$\mu m \times \mu m$
Operation Mode	-	CW, QCW, Pulse ($\tau > 5ns$)	-
Operation Temperature	Top	25	degree
Photo Diode Monitor			
PD Monitor Current		1-1000	μA
PD Reverse Voltage		9	V
TEC			
Maximum Current		5	A
Maximum Operation Voltage		3,8	V
Thermistor			
Resistance		10	kilohm
Wavelength Temperature Coefficient	$\Delta\lambda/\Delta T$	5.5±0.5	Å/degree
Operation Current Temperature Coefficient	$\Delta I/\Delta T$	20±5	mA/degree
Operation Temperature Range		-20... +40	degree
Storage Temperature Range		-40... +80	degree

Output window on the top of HHL (optional)

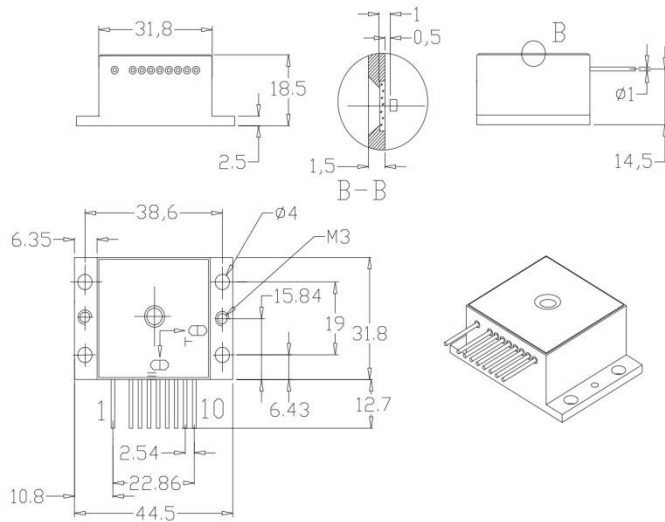

- 1-TEC (-)
- 2-
- 3-
- 4- Laser Anode(+)
- 5- Thermistor (2)
- 6- Thermistor (1)
- 7- Laser Cathode (-)
- 8- PD Anode (+)
- 9- PD Cathode (-)
- 10- TEC (+)

Output window of 0.5 mm in thickness

Output window on the front side of HHL (by default)

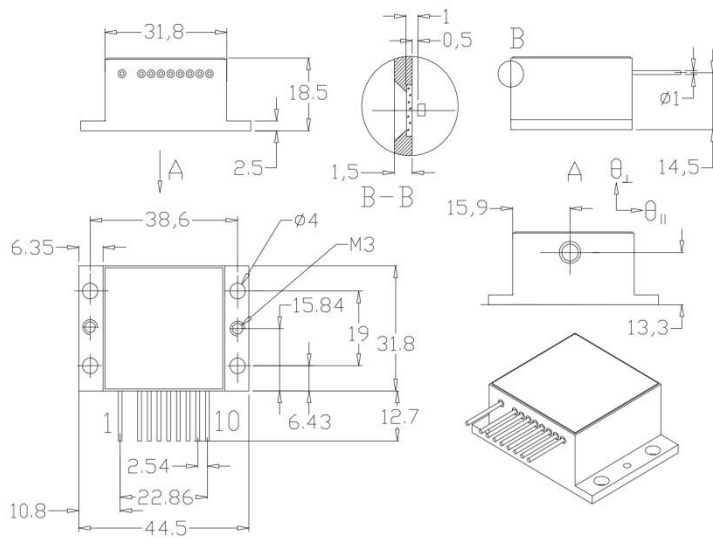

- 1- TEC (-)
- 2-
- 3-
- 4- Laser Anode(+)
- 5- Thermistor (2)
- 6- Thermistor (1)
- 7- Laser Cathode (-)
- 8- PD Anode (+)
- 9- PD Cathode (-)
- 10- TEC (+)

Output window of 0.5 mm in thickness

PRODUCT WARRANTY:

This product is sold with a full one year warranty. The warranty includes all parts and labor. It is warranted to be free from defects in material and workmanship for a period of one year from the date of shipment. The warranty does not include damage to the product due to customer mishandling or use of the product outside of its specified maximum ratings.

INSTALLATION SUPPORT OR TECHNICAL SUPPORT FOR THIS PRODUCT:

800-887-5065 extension 1
contact@laserdiodesource.com



Part of the Laser Lab Source Group:
LaserLabSource.com
LaserDiodeSource.com
LaserDiodeControl.com
Laser Diode Technologies

Laser Lab Source Inc.
1820 W. Lincoln Street
Bozeman, MT USA 59715
contact@LaserDiodeSource.com
contact@LaserDiodeControl.com
800-887-5065

800-887-5065