

Data Sheet

FOL15TCWB-***4-***** / 20mW 1550nm CW Thermally Tunable
DFB Laser Module
Date November 30, 2004 ODC-2V001C



20 mW 1550nm CW Thermally Tunable DFB Laser Module with Integrated Wavelength Monitor (for 25GHz spacing)



Applications

Long Haul or Metropolitan DWDM Transmission Systems

Descriptions

- FOL15TCWB-T series is housed in an industry standard hermetically sealed 14-pin butterfly package, which contains optical isolator, thermoelectric cooler, power monitor photodiode. This series accomplishes a wide tuning range up to 3.2nm using a reliable thermal control. We are offering a good Thermal Electrical Cooler (TEC) technology on the basis of a long history as a leading of 1480nm ultra high power pumping laser modules for EDFA. This series has the same performance as the single wavelength DFB modules of FOL15DCW and plus tunability.
- Our FOL15TCWB-T series has telecommunication-authorized quality based on Fitel's YAG welding techniques. No epoxy and other adhesive.
- Precise wavelength selection is available according to ITU-T grid with 50GHz spaced wavelength allocation. The wavelength can be precisely locked on a certain ITU wavelength by the use of wavelength monitor function and a feedback circuit.

Features

- 8 adjacent channels of 50GHz spacing (16 ch of **25GHz spacing** available)
- Selected wavelength according to ITU-T grid (see Table.1), C and L bands available
- Integrated wavelength monitor function for wavelength locking available
- Industry standard 14-pin butterfly
- Polarization maintaining fiber pigtail
- YAG welding. Epoxy free
- High power operation available with Low Driving Current
- Narrow linewidth in entire tuning range
- High side mode suppression ratio in entire tuning range
- Separate TEC configuration can control a laser and a wavelength monitor, independently
- Extremely small wavelength drift
- Low TEC power consumption

Data Sheet

FOL15TCWB-**4-****-*/ 20mW 1550nm CW Thermally Tunable
DFB Laser Module

Date November 30, 2004 ODC-2V001C

Specifications

Absolute Maximum Ratings

Parameter	Sym	Min	Max	Unit	Conditions
Storage Temperature	Tstg	-40	85	°C	
Operating Case Temperature	Tc	-5	70	°C	
LD Forward Current	I _{FLD}	-	225	mA	
LD Reverse Voltage	V _{rLD}	-	2	V	
PD Forward Current	I _{FPD}	-	5	mA	
Power Monitor PD Reverse Voltage	V _{rpPD}	-	20	V	
Wavelength Monitor PD Reverse Voltage	V _{rwPD}	-	20	V	
TEC 1 Current	I _{tec1}	-	3.4	A	
TEC 1 Voltage	V _{tec1}	-	3.0	V	
TEC 2 Current	I _{tec2}	-	1.5	A	
TEC 2 Voltage	V _{tec2}	-	2.5	V	

Optical Characteristics (TLD=Tset=0-40°C, Tc=25°C, unless otherwise specified)

Parameter	Sym	Min	Typ	Max	Unit	Conditions
Optical Output Power	Pf	20	-	-	mW	
LD Forward Current	If	-	-	160	mA	Pf=20mW, BOL ^{*1}
Submount Temperature	Tset	0	-	40	°C	Pf=20mW
Wavelength Monitor Temperature	Tf	20	-	35	°C	Pf=20mW
LD Forward Voltage	Vf	-	-	2.0	V	Pf=20mW
Threshold Current	I _{Th}	-	-	50	mA	BOL
Wavelength	λ _{ch}	1529.55	-	1611.79	nm	Pf=20mW See Table.1
Module Tuning Range	Δλ	3.2	-	-	nm	Pf=20mW, 0°C≤Tset≤40°C See Table.1
Line Width (-3dB fullwidth)	FWHM	-	-	10	MHz	Pf=20mW
		-	-	5	MHz	Pf=20mW, Optional(-A)
		-	-	2	MHz	Pf=20mW, Optional(-B)
Side Mode Suppression Ratio	SMSR	35	45	-	dB	Pf=20mW
Optical Isolation	Iso	25	-	-	dB	
Relative Intensity Noise	RIN	-	-	-138	dB/Hz	Pf=20mW, OpRL<-25dB ^{*2} 100MHz<f<10GHz
Polarization Extinction Ratio	PER	20	-	-	dB	Pf=20mW, CW
Tracking Error	TE	-0.5	-	0.5	dB	I _m =constant Tc=-5 to 70°C

^{*1}BOL : Beginning of Life

^{*2}OpRL : Optical Return Loss

Data Sheet

FOL15TCWB-***4-***** / 20mW 1550nm CW Thermally Tunable DFB Laser Module

Date November 30, 2004 ODC-2V001C

Thermal Characteristics

Parameter	Sym	Min	Typ	Max	Unit	Conditions
TEC 1 Current	I _{tec1}	-	-	2.2	A	T _c =70°C, Pf=20mW
TEC 1 Voltage	V _{tec1}	-	-	2.9	V	T _c =70°C, Pf=20mW
TEC 2 Current	I _{tec2}	-	-	0.8	A	T _c =70°C, Pf=20mW
TEC 2 Voltage	V _{tec2}	-	-	1.7	V	T _c =70°C, Pf=20mW
Thermistor B constant	B	-	3900	-	K	T _{set} =25°C
Thermistor Resistance	R	9.5	-	10.5	kΩ	T _{set} =25°C

Wavelength Monitor Characteristics(for 50GHz spacing)

Parameter	Sym	Min	Typ	Max	Unit	Conditions
Wavelength Stability to ITU Grid	Δλ _s	-20	-	20	pm	Includes variation due to aging and wavelength tolerance of filter
Free Spectral Range	FSR	-	50	-	GHz	-
Capture Range(negative side)	CR-	5	-	35	GHz	See Fig.1
Capture Range(positive side)	CR+	15	-	45	GHz	
Power Monitor Photocurrent	I _{mon}	15	-	400	μA	Pf=20mW, V _{TPD} =5V
Power Monitor Dark Current	I _{dark}	-	-	100	nA	V _{TPD} =5V
Wavelength Monitor Photocurrent	I _{monλ}	15	-	400	μA	Pf=20mW, V _{rwpd} =5V
Wavelength Monitor PD Dark Current	I _{darkλ}	-	-	100	nA	V _{rwpd} =5V
Wavelength Discriminator Slope	Slope	1	-	20	μA/GHz	-

Wavelength Monitor Characteristics(for 25GHz spacing)

Parameter	Sym	Min	Typ	Max	Unit	Conditions
Wavelength Stability to ITU Grid	Δλ _s	-8	-	8	pm	Includes variation due to aging and wavelength tolerance of filter
Free Spectral Range	FSR	-	25	-	GHz	-
Capture Range(negative side)	CR-	5	-	15	GHz	See Fig.1
Capture Range(positive side)	CR+	10	-	20	GHz	See Fig.1
Power Monitor Photocurrent	I _{mon}	15	-	400	μA	Pf=20mW, V _{TPD} =5V
Power Monitor Dark Current	I _{dark}	-	-	100	nA	V _{TPD} =5V
Wavelength Monitor Photocurrent	I _{monλ}	15	-	400	μA	Pf=20mW, V _{rwpd} =5V
Wavelength Monitor PD Dark Current	I _{darkλ}	-	-	100	nA	V _{rwpd} =5V
Wavelength Discriminator Slope	Slope	1	-	40	μA/GHz	-

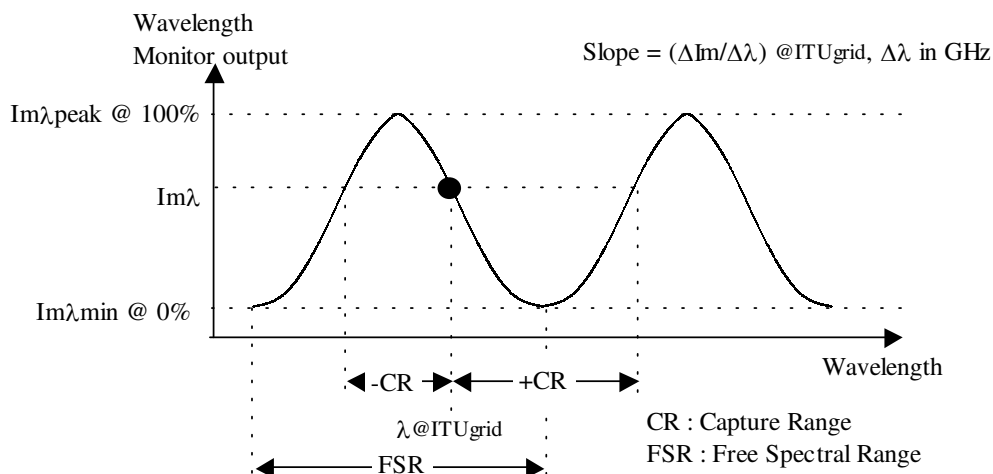

Fig.1 Wavelength discriminator curve

Data Sheet

FOL15TCWB-**4-****-*/ 20mW 1550nm CW Thermally Tunable DFB Laser Module

Date November 30, 2004 ODC-2V001C

Dimensions and Pin Assignments

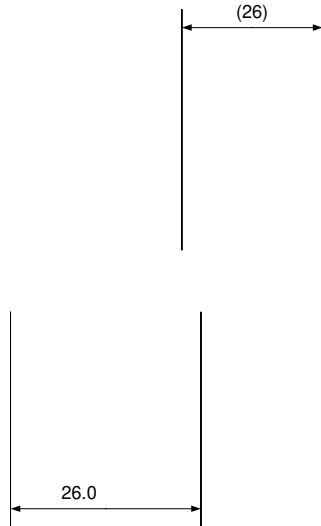

Circuit schematic

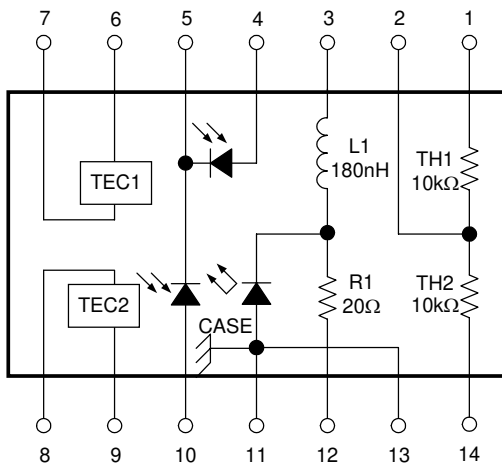

Pin assignments

Pin No.	
1	Thermistor, LD
2	Thermistor, Common
3	Laser DC Bias (Cathode) (-)
4	Power Monitor PD Anode (-)
5	PD Cathode (+), Common
6	Thermoelectric Cooler 1 (+)
7	Thermoelectric Cooler 1 (-)
8	Thermoelectric Cooler 2 (+)
9	Thermoelectric Cooler 2 (-)
10	Wavelength Monitor PD Anode (-)
11	LD anode (+), Case Ground*
12	RF LD Input Cathode (-)
13	LD anode (+), Case Ground*
14	Thermistor, Optical Filter

*LD anode floating available

Data Sheet

FOL15TCWB-***4-***** / 20mW 1550nm CW Thermally Tunable DFB Laser Module

Date November 30, 2004 ODC-2V001C

Optical Fiber Pigtail Specifications

Parameter	Specification	Unit
Fiber Type	FUJIKURA PANDA PM,SM15-P-8/125 UV/UV 400 UV coating (0.4mm φ) or Hyrtel coating(0.9mm φ)	-
Nominal Fiber Length	Min.1,000 (Boot edge (fiber side) to connector edge)	mm
Connector Type	FC/SPC Connector	-
Polarization Axis	Slow Axis	-

Table 1
Example of lists of wavelength band.

Example 1 (for 50GHz spacing)				Example 2 (for 25GHz spacing)			
Part Number	λ [nm]	ITU Frequency [THz]	Wavelength Code	Part Number	λ [nm]	ITU Frequency [THz]	Wavelength Code
FOL15TCWB-T*4-19410	1544.526	194.10	19410	FOL15TCWB-U*4-19410	1544.526	194.100	19410
	1544.924	194.05			1544.725	194.075	
	1545.322	194.00			1544.924	194.050	
	1545.721	193.95			1545.123	194.025	
	1546.119	193.90			1545.322	194.000	
	1546.518	193.85			1545.521	193.975	
	1546.917	193.80			1545.721	193.950	
	1547.316	193.75			1545.920	193.925	
					1546.119	193.900	
					1546.318	193.875	
		1546.518	193.850				
		1546.717	193.825				
		1546.917	193.800				
		1547.116	193.775				
		1547.316	193.750				
		1547.516	193.725				

Customer can select their required ranges from 1529.55 to 1611.79.

Wavelength values are referenced to vacuum. 25GHz spacing is also available.

Wavelength (λ) and ITU frequency (f) have a relationship of $\lambda \text{ [nm]} = 299792458 / f \text{ [THz]} / 1000$.

FITEL wavelength code is expressed as a 5-digit integer rounded from $100 \times f \text{ [THz]}$.

Data Sheet

FOL15TCWB-**4-***** / 20mW 1550nm CW Thermally Tunable
DFB Laser Module

Date November 30, 2004 ODC-2V001C

Ordering Information

FOL15TCWB

Wavelength code

Linewidth

N/A: <10MHz

A: <5MHz

Safety Information

This product complies with 21 CFR 1040.10 and 1040.11, Class 3b laser product. Invisible laser radiation is emitted from the end of the fiber or connector. Avoid direct exposure to the beam



Furukawa Electric Co, Ltd., Furukawa America, Inc, and Furukawa Electric Europe, Ltd. reserve the right to change data contained in this document in the interest of continued product improvement. The publication of this information does not imply freedom from patent or any other rights of The Furukawa Electric Company, Ltd. or its affiliated companies.

All Rights Reserved, Copyright © THE FURUKAWA ELECTRIC CO., LTD

FITEL

Headquarters
6-1 Marunouchi 2-chome
Chiyoda-ku Tokyo
100-8322 Japan
T: 81-3-3286-3253
F: 81-3-3286-3978
www.furukawa.co.jp

Furukawa Electric Europe, Ltd
3rd FL Newcombe House
43-45 Notting Hill Gate
London, W11 3FE
UK
T: 44-20-7221-6000
F: 44-20-7313-5310
www.furukawa-fitel.co.uk
sales@furukawa-fitel.co.uk

Furukawa America, Inc.
Perryville Corporate Park
Perryville III
Clinton, NJ 08809
USA
T: 908-713-3525
F: 908-713-3515
www.furukawaamerica.com
oesales@furukawaamerica.com