

LCM155EW-64

10Gb/s co-packaged Etalon stabilised laser with integrated III-V Mach-Zehnder modulator

Features

Voltage programmable output power control.

Long haul performance with negligible penalty.

Integral Etalon wavelength stabilisation to within $\pm 20\text{pm}$ over life.

Differential or single 50 Ohm low voltage drive modulation input.

Integral thermo-electric cooler with precision NTC thermistor for temperature control.

Hermetically sealed butterfly style package with SMA RF connectors.

ITU Wavelengths available from 1530nm to 1560nm.

Applications

Long reach SONET/SDH STM64/OC192 DWDM systems to 50GHz channel spacing

Description

The LCM155EW-64, containing the Nortel Networks Strained Layer MQW DFB laser chip and the III-V Mach-Zehnder modulator chip, has been designed specifically for use in 10 Gbit/s long distance optical fibre trunk systems. Thermo-electric heatpumps, a precision NTC thermistor and optical isolator are incorporated, and rear facet monitoring provides wavelength locking to the ITU grid. The module is capable of >80km transmission over Non Dispersion-Shifted Fibre (NDSF) without additional

dispersion compensation. This is achieved by the negative chirp characteristic which compensates for 1500ps/nm dispersion. Increased transmission distances are achievable using dispersion shifted fibre with or without dispersion compensation. Optical power control is achieved by applying a D.C. bias voltage to the internal attenuator electrode. This reduces the power into the modulator section without affecting the operating wavelength.

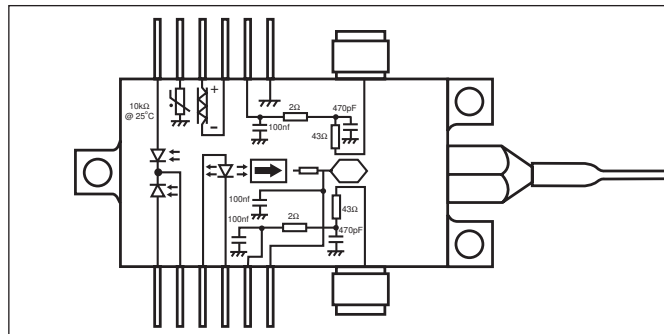

LCM155EW-64

Characteristics

Conditions unless otherwise stated: Submount temperature $30^{\circ}\text{C} \pm 5^{\circ}\text{C}$ (for locked λ)
Monitor diode bias -5V
Output power (mean) 0dBm min.

Parameter	Conditions	Min	Typ	Max	Unit
Threshold current (I_{th})				40	mA
Slope efficiency		3.7	6		$\mu\text{W}/\text{mA}$
RF input reflection coeff. (S_{11})	to 8GHz	10			dB
Laser Forward voltage				2.8	V
Peak wavelength	ITU Grid	1527.22		1563.86	nm
Sidemode suppression ratio		40			dB
Optical rise/fall time	(20% - 80%)			50	ps
Monitor photocurrent	@ locked λ	0.15			mA
Monitor dark current				100	nA
Thermistor resistance	@ locked λ	6.81		10.09	k Ω
Heatpump current	T_{case} 0-70°C			1.8	A
Heatpump voltage	T_{case} 0-70°C			5	V
M - Z bias voltage (left arm)	@ <12mA	-4	-2	-1.5	V
M - Z bias voltage (right arm)	@ <12mA	-5		0	V
Modulation voltage	a.c. p-p	3	4	5.5	V
Extinction ratio	ac		13		dB
Attenuator voltage (0 - 15dB)	@ <30mA	-7.3		0.5	V
Dispersion penalty	1500ps/nm			1	dB

Absolute Ratings

Parameter	Conditions	Min	Typ	Max	Unit
Operating temperature		0		70	$^{\circ}\text{C}$
Storage temperature		-40		85	$^{\circ}\text{C}$
Laser forward current				275	mA
Laser reverse voltage				2	V
Monitor diode bias				15	V
TE cooler current				1.8	A
Mach-Zehnder bias voltage		-6		0.5	V
Attenuator voltage		-7.3		0.5	V
Fibre bend radius		30			mm

LCM155EW-64
10Gb/s co-packaged Etalon
stabilised laser with integrated
III-V Mach-Zehnder modulator

Outline Drawing

Dimensions in mm

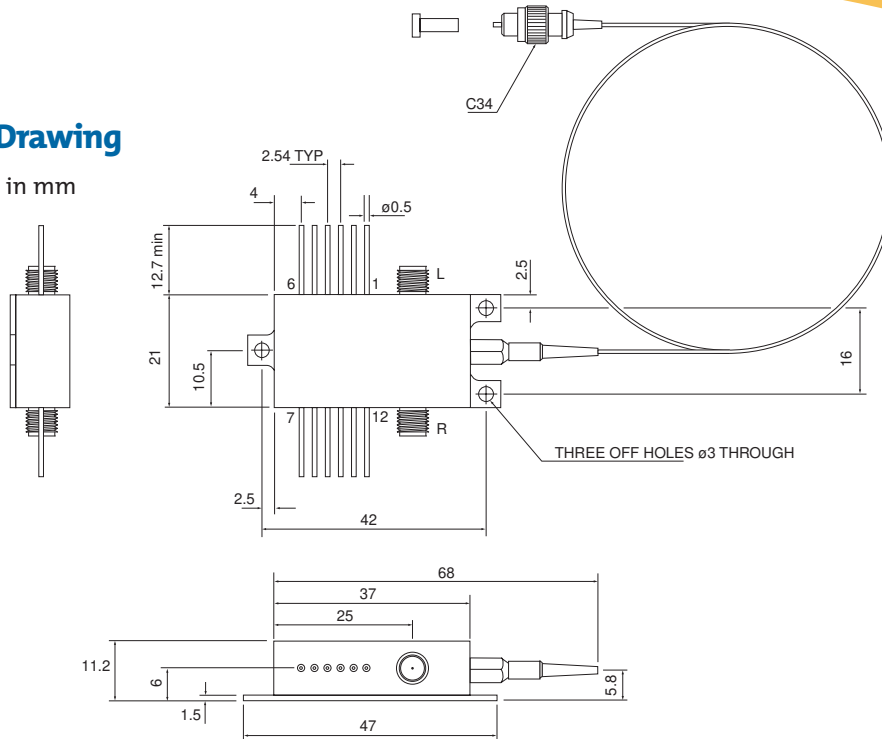

Instructions for Use - LCM155EW-64

Pin 1 Ground

Package ground pin.

Pin 2 MZ Bias Left and Pin 11 MZ Bias Right

DC bias voltages for left and right MZ arms. These pins must be connected to a negative DC voltage (typically around -2 V) which is defined in the deliverable data. The bias voltage source must be capable of delivering up to 10 mA to each pin.

Pin 3 TEC (-) and Pin 4 TEC (+)

The package contains two peltier heatpumps connected in series. Applying a negative voltage on Pin 3 with respect to Pin 4 will cause the internal optics to be cooled relative to the case temperature. Reversing the applied voltage will cause the internal structures to be heated. The power supply for the heatpumps should be capable of sourcing up to 2 A at 5 V.

Pin 5 Thermistor

The thermistor is used in the control loop for keeping the internal

temperature at a constant value. It has a nominal resistance of 8.2 k Ω at the typical operating temperature of 30 °C and is not polarity sensitive, although one side of the thermistor is connected to package ground. Operating current should be limited to less than 100 μ A to prevent self-heating errors. The exact thermistor value will be supplied with the LCM155EW variant to ensure correct operating wavelength.

Pin 6 Monitor Anode (short), Pin 7 Monitor Anode (long) and Pin 8 Monitor Cathodes

The two back facet monitor diodes are used in a control loop, which maintains constant laser wavelength. Each diode has a different spectral response, which overlaps at the “locked” wavelength. The loop can control submount temperature and laser bias to maintain the two monitor diode currents at equal values. The diodes are operated with a reverse 5 V bias.

Pin 9 Laser Anode and Pin 10 Laser Cathode

The laser is operated with a forward

bias current up to 275 mA at 2.75 V (typical). Threshold current is typically 30 mA at 30 °C.

Pin 12 Attenuator

A negative DC voltage in the range 0 V to -7.3 V applied to this pin will attenuate the output power by up to 15.5 dB. The supply should be capable of sinking up to 30 mA from this pin.

MZ Data Left

Single-ended data input with typical amplitude of 4.0 Vpp is applied via the SMA connector (the required value for optimum performance is supplied with the device). Input must include a DC block.

MZ Data Right

When operating the module with a differential input, data is applied to both left and right arms. Typical amplitude is 3.0 Vpp in this mode.

LCM155EW-64

Package Pinout

SMA	MZ Left Data	SMA	MZ Right Data
Pin 1	Ground	Pin 12	Attenuator
2	MZ Bias Left	11	MZ Bias Right
3	TEC (-)	10	Laser Cathode
4	TEC (+)	9	Laser Anode
5	Thermistor	8	Monitor Cathodes
6	Monitor Anode (short)	7	Monitor 2 Anode (long)

Device Ordering Information

Order code no. LCM155EW****-64

Where **** = last four digits of wavelength value.
(i.e for $\lambda_p = 1557.36\text{nm}$, **** = 5736)

For wavelength information see Nortel Networks WDM wavelength plan.

FC/PC connector supplied as standard.
Standard fibre length $1500 \pm 100\text{mm}$.
Other connector types are available on request.

Nortel Networks High Performance Optical Component Solutions

Brixham Road
Paignton
Devon
TQ4 7BE
United Kingdom
Tel: +44 1803 662106
Fax: +44 1803 662801

Email: opticalcomponents@nortelnetworks.com
www.nortelnetworks.com/hpocs

All data in this document is subject to change in accordance with Nortel Networks Corporation policy of continual product improvement. No data in this document is intended to be used in connection with any contract except as may be first confirmed in writing by Nortel Networks Corporation. The publication of information in this document does not imply freedom from patent or other rights of Nortel Networks Corporation or others.
© 2000 Nortel Networks. All rights reserved.
© Nortel Networks, Nortel Networks Logo, the Globemark and Unified Networks are trademarks of Nortel Networks.
Information in this document is subject to change without notice. Nortel Networks assumes no responsibility for errors that might appear in this document.
Printed in England.

NORTEL
NETWORKS™



CLASS 1 LASER PRODUCT

REFERENCE IEC 825-1:1993



THIS PRODUCT COMPLIES WITH 21 CFR 1040.10

CAUTION - USE OF CONTROLS OR ADJUSTMENTS OR PERFORMANCE OF PROCEDURES OTHER THAN THOSE SPECIFIED HEREIN MAY RESULT IN HAZARDOUS RADIATION EXPOSURE

