

14-Pin Butterfly Package ZIF Laser Diode Mount and Heat Sink / BTY-T1-D9-ZIF



LOW COST BUTTERFLY LASER DIODE MOUNTING AND HEAT SINK SOLUTION

- ◇ Compact Air-Cooled Laser Diode Mount
- ◇ Type-1 Laser Diode Wiring Configuration
- ◇ Shorting Jumper for ESD Protection

KEY SPECIFICATIONS

- Connector: D-Sub, 9-Pin
- Pinout: Type-1 (Pump Laser)
- Photodiode Connectivity: Floating PD
- Maximum TE Current: 3 Amps
- Maximum Laser Current: 3 Amps
- Laser Mounting Screws: 4x M2.5 HEX (included)
- Dimensions (mm): 66 x 50 x 43

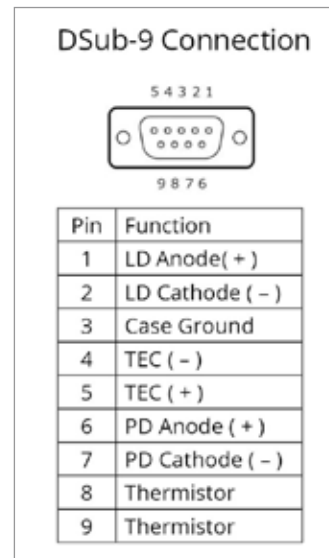
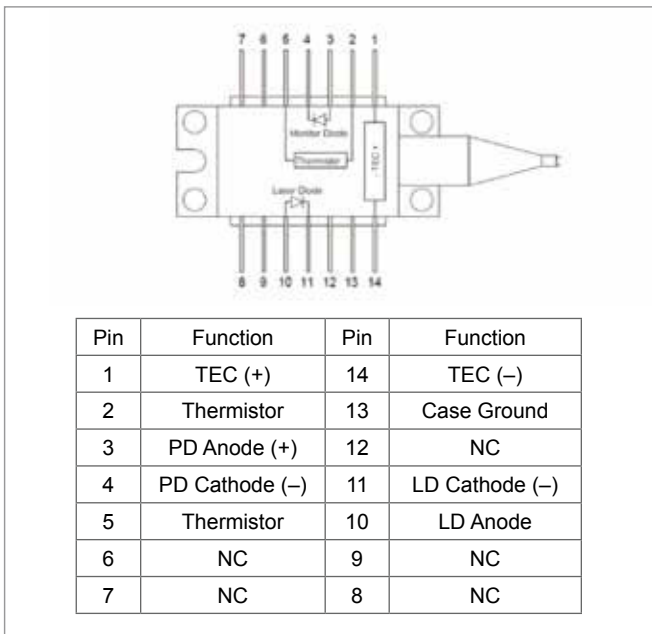

Instructions for Use

Thermal Considerations

In order to maintain constant laser diode chip temperature, a TEC is integrated into the laser diode package. To properly utilize the internal TEC with this mount and heat sink, there must be good thermal contact between the laser package and the heat sink. The use of thermal interface material between the laser diode package and the heat sink is strongly recommended. A good quality thermal grease or thermal interface pad can be used for this purpose.

Butterfly Package, Soldering to the Mount PCB

Important! The laser diode can be damaged by ESD. Always take precautions to protect the laser diode by working in an ESD safe environment.

1. Apply a small amount of thermal grease on the butterfly laser package base where it will contact the heat sink. A thin coating of thermal grease is sufficient; there should be no thick spots or build-up. Alternately a thermal interface pad can be used.
2. Open the butterfly pin clamp arms by loosening the thumb screws so that the clamp arm can be moved off of the spring contacts on the PCB.
3. Insert the butterfly laser diode into the PCB. Mind the orientation of the laser package: the square solder pad and small white dot on the top of the PCB indicate Pin 1 of the laser package.
4. The package should be secured to the heat sink using all four screws. The screws should be tightened evenly in two stages. The package can be permanently distorted and damaged if the screws are tightened unevenly or over-tightened.
5. Replace the plastic clamp arms over the pins of the package and tighten the thumbs screws. Finger-tight is sufficient; do not overtighten.

Notes

1. The JP1 jumper is installed by default and is protects the laser diode from ESD damage by shorting the anode and cathode. Install the JP1 jumper when the laser diode not in use or is disconnected from the current source.
2. Make sure to remove JP1 jumper after connecting the mount to the laser source and before switching on the laser diode current source.



Offered by
LASER LAB SOURCE



**LASER DIODE
HEAT SINKS**

PRODUCT SALES AND SERVICE:

Unlimited phone and email support is provided for products purchased through Laser Lab Source. Orders for this product are fulfilled by Laser Lab Source in North America and select international regions.

PRODUCT WARRANTY:

This product is sold with a full one-year warranty. It is warranted to be free from defects in material and/or workmanship for a period of one year from the date of shipment.



Laser Lab Source, a division of Research Lab Source, Inc.
1820 W. Lincoln Street
Bozeman, MT 59715 USA

Phone: 406-219-1472

www.LaserLabSource.com

Manufactured for Laser Lab Source by **ELOP Tech**