

1030 & 1064 nm SOA

1030/1053/1064 nm / PM singlemode fiber / Butterfly package

Reference: SOA-2-0-0

SPECIFICATIONS	Unit	Min	Typ	Maximum
Amplification/Modulation Wavelength	nm	1000		1100
Operating Current (CW mode)	mA		400	500
Operating Current (Pulse mode*)	mA		1000	1200
Max output power (1064 nm-CW mode)	mW/dBm		100/20	
Max output power (1064 nm-Pulse mode*)	mW/dBm		200/23*	
Operating Voltage	V		1.7	
ASE optical 3 dB Bandwidth	nm	70	90	
Small signal gain (Pin = -25 dBm / 3 μW)	dB	29	33	
Gain Ripple (RMS) @ IopCW	dB		0.03	0.2
Extinction ratio (Pin=-25 dBm)	dB	50	75	
Noise Figure (NF)	dB		5.0	
TEC current (25°/case@65°)	A			3.0
TEC voltage (25°/case@65°)	V			4.0
Internal thermistor (25°) – (Beta=3375 K)	kOhm	9.5	10.0	10.5
Fiber type (eq)	-	Panda PM980		
Fiber coating	μm	250		
Connectors		FC/APC		
Fiber bend radius	kgf			1
Storage temperature	°C	-40		+85
Operating case temperature	°C	-20		+70
Operating chip temperature	°C	+15		+45
Laser diode reverse voltage	V			2
Soldering temperature/time	°C/S			260/10

*With AeroDIODE pulsed drivers only

Form factor, SOA pinning and typical performances :

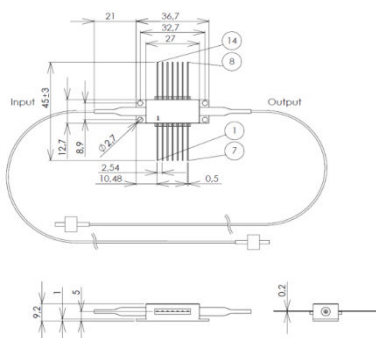

Pin identification:

- 1 TEC "+"
- 2 Thermistor
- 3 -
- 4 -
- 5 Thermistor
- 6 -
- 7 -
- 8 -
- 9 -
- 10 SOA anode "+"
- 11 SOA cathode "-"
- 12 -
- 13 Case
- 14 TEC "-"

Gain spectra at different input signals

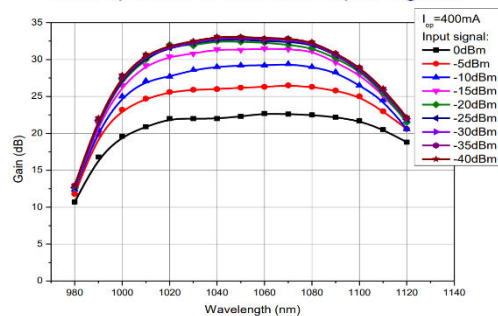

Gain spectra at different currents

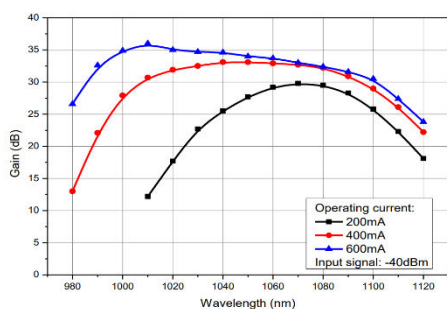

Gain and Output power vs. input signal

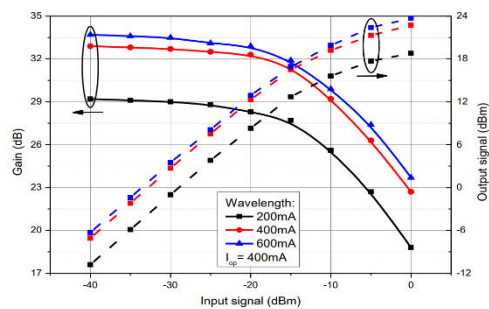

33400 Talence - France - Tél. : +33 (0)6 27 69 41 52

contact.aerodiode@aerodiode.com - www.aerodiode.com

SIRET 880 329 636 00018 - N° TVA intracommunautaire : FR 87880329636