

1310 nm SOA

1310 nm / PM singlemode fiber / Butterfly package

Reference: SOA-3-0-0

SPECIFICATIONS	Unit	Min	Typ	Maximum
Amplification/Modulation Wavelength range	nm	1270	1310	1330
Operating Current (CW mode)	mA		700	750
Operating Current (Pulse mode*)	mA		1000	1200
Max output power (1310 nm-CW mode)	dBm		18 (65 mW)	
Max output power (1310 nm-Pulse mode*)	dBm		20* (100 mW)	
Maximum input power	dBm			15
Operating Voltage	V		1.7	
ASE optical 3 dB Bandwidth	nm	50	60	
Small signal gain (Pin = -25 dBm/3 μW)	dB	28	30	
Gain Ripple (RMS) @ IopCW	dB		0.1	
Extinction ratio (Pin = -25 dBm)	dB	50	75	
Noise Figure (NF)	dB			7.0
TEC current (25°/case@65°)	A			1.5
TEC voltage (25°/case@65°)	V			3.6
Internal thermistor (25°) - (Beta=3375 K)	kOhm	9.5	10.0	10.5
Fiber type (eq)	-	Panda PM1310		
Fiber coating	μm	900μm		
Connectors		FC/APC		
Fiber bend radius	kgf			1
Storage temperature	°C	-40		+85
Operating case temperature	°C	-20		+70
Operating chip temperature	°C	+15		+45
Laser diode reverse voltage	V			2
Soldering temperature/time	°C/S			260/10

*With AeroDIODE pulsed drivers only- permanent damage may occur otherwise.

Form factor, SOA pinning and typical performances :

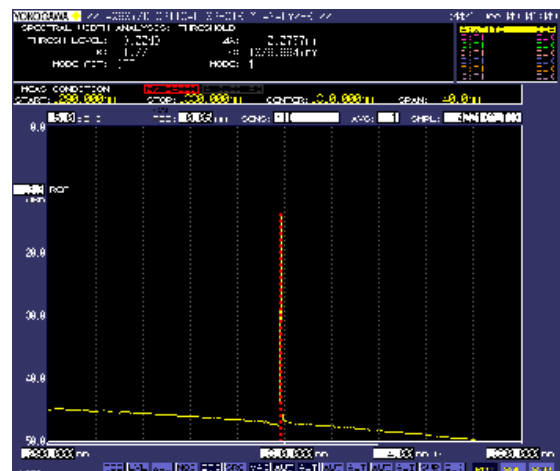
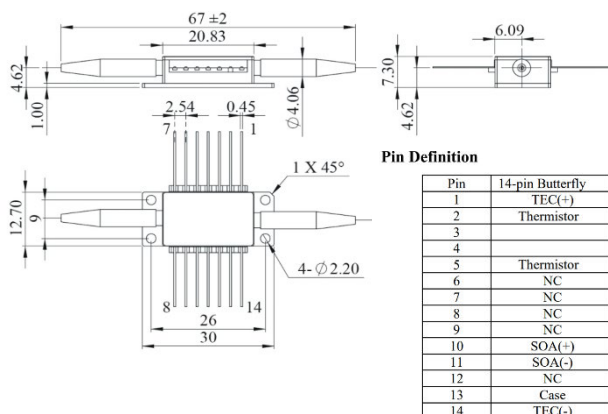

Typical spectrum of a 1310 nm DFB laser diode amplified in pulsed mode (OSA resolution 0.05 nm).