

Free-space AOM (Acousto-Optic Modulator)

Standard 80 MHz version – 1650 nm

Reference: 1650FSAOM-80-0.7

Technology/Crystal: TeO₂*

SPECIFICATIONS	Unit	Min	Typ.	Max	Comments
AOM Material			TeO ₂		
Wavelength	nm	1400	1650	1700	Customizable
RF Frequency	MHz		80		
Active Aperture	mm		0.7		
Input impedance	Ω		50		
Frequency shift	MHz		80		
RF Power	W		2.5		
Max Optical Input CW/average Power	W			15	
Max Optical Power/surface	MW/cm ²			50	
Efficiency (optimized beam conditions)	%	75	80		
Rise/fall time (beam 250 μm)	ns		40		
Rise/fall time (beam 100 μm)	ns		16		
Crystal coating transmittance (per surface)	%	99.5			
Electrical input interface			SMA		
Working temperature	°C	-20		60	
Storage temperature	°C	-30		70	
Dimensions	mm ³	41.8*25*13.5			
Mounting holes diameter	mm		2*M2		

*: See our tutorial: [fiber modulator](#)

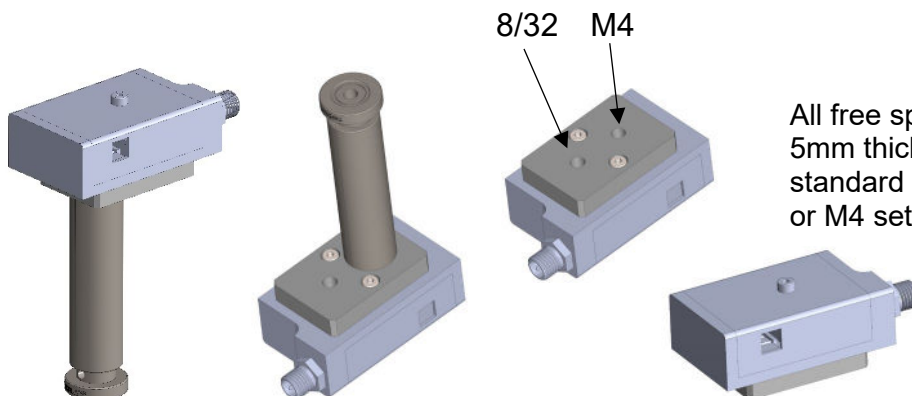
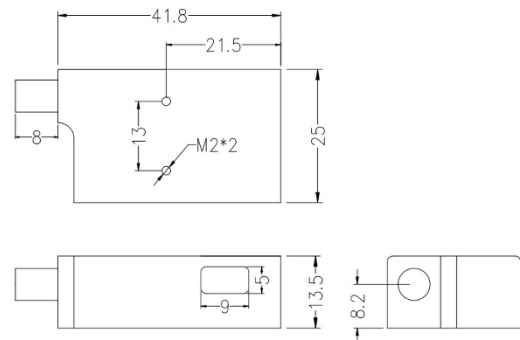

All free space AOMs are supplied with a 5mm thick adapter plate compatible with standard pedestal bases with either 8/32 or M4 setscrews.